

C-Class Saloon and Estate



Mercedes-Benz



“Refinement, design, safety... the C-Class is
a thoroughbred Mercedes. C for yourself!”

Dr. Dieter Zetsche



Contents

The C-Class	4	My C-Class	50		
Driving	10	Lines	51	Technical	98
BlueEFFICIENCY	12	SE	52	Technical data for Saloon	98
Diesel engines	14	Executive SE	58	Dimensions of Saloon	100
Petrol engines	16	Elegance	60	Technical data for Estate	102
Transmissions	19	Sport	66	Dimensions of Estate	104
Suspension	20	Design and equipment lines	72	Service	106
Comfort	24	Equipment	74	Test drive	110
Interior	24	Standard equipment for Saloon	74		
Cockpit	26	Alloy wheels	76		
Seat comfort	27	Audio systems	80		
COMAND	28	Optional extras for Saloon	81		
Ride comfort	30	Standard equipment for Estate	84		
Load compartment	32	Optional extras for Estate	85		
Safety	36	Retailer-fit accessories	86		
The integral safety concept	36	Colours and materials	90		
AMG	43	Paint finishes	92		
		Upholstery	94		
		Trim	96		
		Combination options	97		



A driving sensation

The C-Class

The road has always felt more special in a Mercedes. And with the C-Class, it feels better than ever. From interior to engines, this is a car designed to respond rapidly and precisely – both to its surroundings and to you. Its wide range of engines offers increased outputs, and the standard-fit Agility Control Suspension with Adaptive Damping System further enhances the car's responsiveness. Another technological highlight is the Dynamic Handling Package with sport mode, an option which gives drivers more dynamic handling at the touch of a button.

Inside, there's more space for you and your passengers and, in the Estate version, more space for luggage too, thanks to the large and versatile load compartment. And because a Mercedes means quality and not just quantity, there's also the elegant cabin design with a refined ambience and superior materials. What's more, the C-Class lets you decide just how sporty or luxurious its cabin should be, and even what kind of face it should have, making it easier than ever to create the ideal C-Class for you.







A unique personality

The C-Class Sport

The C-Class is as striking on the outside as it is on the inside: distinct design lines, ample cabin space and high-quality materials. It not only boasts a wide range of exterior colours and interior trim, the C-Class offers a choice of personalities, too.

The Sport line, for instance, highlights the dynamic nature of the C-Class. The prominent three-pointed star in its grille creates a powerful first impression, the standard AMG bodystyling and 17" AMG 6-twin-spoke alloy wheels make for a muscular look all round, and the drive more than lives up to the exterior's promise.



And distinctive characters

The C-Class Elegance, SE and Executive SE

The Elegance line brings out the luxurious side of the C-Class. Its three-pointed star sits proudly on the bonnet and its extensive chrome exterior trim adds an extra touch of class. The cabin is carefully colour-coordinated and exudes a warm, inviting ambience.

The SE line, too, boasts a bonnet-mounted three-pointed star. It's also generously equipped and offers everything you'd expect of a Mercedes-Benz – such as high-quality materials, a beautifully appointed cabin and a handsome exterior, set off by attractive alloy wheels.

With the new C-Class Executive SE, you can travel in style every single day. Its refined lines are beautifully set off by striking new alloy wheels, while the grille-mounted three-pointed star makes for an equally eye-catching front end. What's more, this special edition is as attractive inside as out, thanks to a generously equipped cabin featuring the COMAND multimedia system as standard.







The C-Class



Enjoy the drive of a lifetime. Every single day

A dynamic look, and the handling to match

The C-Class is instantly captivating. Its taut lines give it an effortless style, while the wide grille and distinctive rear create an unmistakably dynamic presence. And yet the exciting looks are only half the story.

Under the skin, the C-Class boasts a host of technological innovations that combine to deliver a peerless driving experience. One such innovation is the Agility Control

Suspension with Adaptive Damping System (standard on all models), which automatically adjusts the suspension settings to the road, ensuring optimum driving enjoyment at all times. Then there's the optional Dynamic Handling Package with sport mode. It lets you decide what kind of a drive you want – by switching from comfort-orientated to sporty at the touch of a button.



BlueEFFICIENCY – technology for more efficient driving

As the inventor of the motor car, we feel we have a special responsibility for improving its resource efficiency – without compromising on safety, comfort and driving pleasure.

Our comprehensive BlueEFFICIENCY measures have already brought significant cuts in fuel consumption to many current Mercedes-Benz models, helping to lower both their CO₂ emissions and their running costs. What's more, we are continuing to develop new environmentally friendly technologies that will reduce emissions even further and help to make motoring more sustainable in the long term.

BlueEFFICIENCY – the Mercedes-Benz efficiency drive. In addition to highly advanced and efficient engines, BlueEFFICIENCY models come with a range of energy-saving measures that enable fuel

consumption and CO₂ emissions to be reduced by up to 23%. These measures vary from model to model but can include ECO start/stop, on-demand ancillary components and low-resistance tyres, as well as aerodynamic optimisation and the use of lightweight materials.

BlueTEC – cleaner diesel power. BlueTEC is our cleanest diesel technology to date. Its combination of advanced common-rail direct injection, optimised combustion and modular emissions control systems reduces particulate levels by up to 95% and removes up to 90% of nitrogen oxides, leaving little but water, harmless nitrogen and the satisfaction of knowing you've done your bit for the environment. BlueTEC models will be introduced to the S-Class and E-Class Saloon ranges in 2010. Please ask your local Retailer for more details.

HYBRID and BlueTEC HYBRID – the future of internal combustion. The next stage in our efficiency drive, hybrid drivetrains will bring new levels of fuel efficiency and emissions reduction to tomorrow's Mercedes-Benz passenger cars. The petrol/electric **HYBRID** system allies an economical internal combustion engine to an electric motor that not only assists the engine when accelerating but also recovers kinetic energy during braking. In addition, the system automatically shuts off the engine as the car slows to a standstill, helping to reduce fuel



BlueTEC filters out up to 95% of particulates and converts up to 90% of nitrogen oxides into harmless nitrogen

consumption even further. The diesel equivalent, **BlueTEC HYBRID**, combines the benefits of hybrid drive with the clean-burn technology of BlueTEC. It achieves outstanding fuel economy while keeping harmful emissions to a minimum.

BlueZERO – the drivetrains of tomorrow.

The BlueZERO concept showcases three highly developed electric vehicle variants. The E-CELL is an all-electric system driven solely by the battery, E-CELL PLUS pairs battery power with a range-extending internal combustion engine,



The HYBRID system lowers fuel consumption by up to 20%

while the F-CELL features a hydrogen-based fuel-cell stack.

Design for Environment. Our environmental philosophy is not just about in-car technologies. It also involves taking the entire lifecycle of each vehicle into account, from its initial planning to its end-of-life recycling. We apply the same approach to the building and maintenance of new factories too, saving energy, avoiding harmful emissions and making increasing use of renewable resources.

In addition, Mercedes-Benz is involved in the development of alternative fuels and conducts research in the field of bionics. For more information about what BlueEFFICIENCY can do for you, please visit

www.mercedes-benz.co.uk/blueefficiency

Engines with the power to move you

The common-rail C-Class diesel engines

The C-Class offers a choice of four diesels, all with common-rail injection technology. The top performer is the C 350 CDI BlueEFFICIENCY. This 6-cylinder produces 231 hp (170 kW) and accelerates from 0 to 62 mph in 6.4 seconds (or 6.5 seconds in Estate guise).

The 4-cylinder engines have benefited from a range of technical refinements, including larger oil jets to improve piston cooling and the introduction of ceramic glow plugs, which reach higher temperatures than their metal counterparts and hence improve cold starting.

Without compromising on power, the twin turbocharger C 220 CDI BlueEFFICIENCY SE manual delivers 170 hp

(125 kW), while attaining 58.9 mpg in the combined cycle, and just 127 g/km of CO₂ emissions. Similarly, the new C 250 CDI BlueEFFICIENCY SE manual has an output of 204 hp (150 kW) and manages 55.4 mpg combined and 134 g/km. Both BlueEFFICIENCY engines achieve the stringent EU5 emissions standard. Our C 200 CDI BlueEFFICIENCY manual has an output of 136 hp (100 kW) and 56.5 mpg in the combined cycle.



BlueEFFICIENCY models, engineered to reduce fuel consumption and for lower CO₂ emissions



Discover a different kind of performance reward

The 4-cylinder petrol engines

Opt for one of the three petrol-engined C-Class models and excellent performance is assured. The 4-cylinder models get the range off to an impressive start, with a choice between the supercharged C 180 KOMPRESSOR BlueEFFICIENCY manual, exclusively available on the Executive SE, or the turbocharged C 180 CGI BlueEFFICIENCY manual with ECO start/stop, both offering 156 hp (115 kW).

For power and torque increases, thanks to effective engine management software and pistons, choose the turbocharged C 250 CGI BlueEFFICIENCY which delivers 204 hp (150 kW) and 310 Nm. On the road that translates to improved performance, with 0–62 mph now taking 7.4 seconds (7.5 seconds in the Estate) and top speeds of 149 mph (145 mph in the Estate).



Watch the scenery fly quietly by

The V6 petrol engine

A V6-engined C-Class is a truly civilised way to travel fast. The C 350 offers a perfect blend of refinement and power. It combines outstanding performance with superb comfort, producing some 272 hp (200 kW) and accelerating from 0 to 62 mph in just 6.4 seconds (6.5 seconds in Estate form). Providing a responsive drive even at low speeds, the C 350 delivers a maximum torque of 350 Nm across a wide rev range.

Fuel consumption is similarly civilised. The four continuously variable camshafts ensure exactly the right amount of fuel is used in any given situation, resulting in more efficient combustion.

From the outside, a twin exhaust system with single tailpipes each side sets the V6 model apart and emphasises its discreet muscularity.

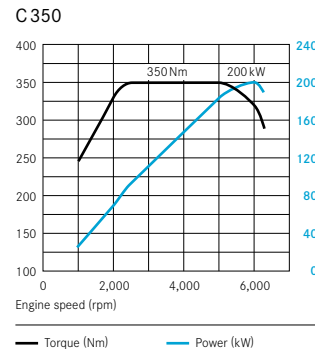

C 350: The most powerful V6 engine of the C-Class range boasts 272 hp (200 kW) and peak torque of 350 Nm



When it comes to innovation, we always seem to find an extra gear

The C-Class transmissions

All 4-cylinder C-Class models come with 6-speed manual transmission as standard and offer 5-speed automatic transmission as an option (except for the C 250 CGI BlueEFFICIENCY, which has 5-speed automatic transmission as standard). With its short, precise throws, this slick manual transmission ensures gear changes are always a pleasure. In addition, manual models feature a Hill Start Assist function that helps you to pull away smoothly on steep inclines by applying the brakes for a split second, allowing you to move your foot from the brake to the accelerator pedal without using the parking brake. The C 350, C 350 CDI BlueEFFICIENCY and C 63 AMG have 7G-Tronic 7-speed automatic transmission as standard. 7G-Tronic's extra forward gears enable it to maintain optimum revs at all times and deliver almost imperceptible shifts. It can also change down more than one gear at a time when a more urgent response is required.



Manual or automatic?

How about both? Enjoy manual shifts on automatic models by just nudging the gear shift lever to the left or right

Sporty or soothing?

Tailor the driving experience to your mood

The Dynamic Handling Package

One of the key innovations in the C-Class is the Dynamic Handling Package with sport mode that's available as an option for the Sport line. This electronically controlled system continually adjusts damping levels to the road surface and driving situation, increasing ride comfort, safety and, above all, agility. The features of the Dynamic Handling Package are fully automatic, but they can also be influenced manually via sport mode. It enables you to switch to firmer damper settings and a more direct throttle response at the push of a button. And when you're no longer in the mood, just change to comfort mode and you'll enjoy a smooth and effortlessly relaxing ride.



Sport mode: the Dynamic Handling Package's sport mode lets you change the driving experience to suit your mood, switching to a more dynamic set-up at the touch of a button and, if your C-Class is fitted with automatic transmission, giving you even quicker gear shift changes





C 350



D S ON3811





Why long journeys may suddenly seem too short

The spacious and supremely comfortable C-Class cabin

With its high-quality materials, fine trim and increased space, the C-Class interior is an invitation that's impossible to resist. The driver sits slightly higher and enjoys significant shoulder and elbow room. Rear seat passengers, too, will feel quite at home, thanks to improved leg room in the rear.

The cabin is full of attractive details such as chrome highlights and High-Gloss Black, Eucalyptus wood or aluminium trim, depending on the model you choose. And there are a host of options that enhance the cabin ambience even further – such as the panoramic sunroof. With glass all the way from front to rear windscreen, it creates a truly special atmosphere inside.

It also keeps the cabin almost completely draught-free when open, thanks to its wind deflector design.



Sitting comfortably: The seats look inviting and they don't disappoint, offering excellent levels of comfort and support



How to maximise control? Let others take the strain

Stress-relieving comfort in the C-Class

Freedom from stress and strain enhances not only your comfort, but your concentration too. Which in turn makes for safer driving. One of the key factors in stress-free driving is the ergonomics of your car's instruments and controls. In the C-Class, they are clearer and easier to use than ever. The higher-set fascia has a horizontal layout and the three circular instruments give you all the key information at a glance. In addition, the buttons on the multi-function steering wheel allow you to control various functions without taking your hands off the wheel.

There's no need to constantly adjust your temperature settings in the C-Class either. Its two-zone automatic climate control system maintains your ideal cabin temperature at all times. The optional three-zone luxury

automatic climate control even allows the temperature in the rear to be controlled separately.



At your fingertips: The C-Class controls are entirely intuitive. From in-car audio to temperature settings, the key functions can be operated at the push of a button

Your new favourite chair

The exceptionally comfortable C-Class seats

The ergonomic front seats of the Elegance and SE models (and the figure-hugging sports seats of the C-Class Sport) all feature electric height and backrest angle adjustment as standard, plus adjustable lumbar supports. With the optional Memory Package, the driver and front passenger seat settings can even be stored and recalled automatically – along with the position of your steering wheel, front head restraints and exterior mirrors.

Other options include heated front seats, leather upholstery and multi-contour seats with adaptive air cushions that provide additional support.



A navigation system that's a real turn for the better

The COMAND multimedia navigation system

The optional COMAND multimedia system¹ combines the controls and displays for the in-car audio, telephone and navigation systems. Despite boasting a wide range of functions, the COMAND system is as intelligent and user-friendly as ever, thanks to a streamlined set of controls. In addition, its electrically folding 7-inch screen features high resolution graphics and colours and is at the same height as the instrument panel, making it ideally positioned for the driver's field of vision.

The COMAND system can be operated either via the control panel in the middle of the centre console or via the controller situated in front of the armrest. All key functions can also be operated via the integrated Linguatronic voice control system: the system can understand all road and place names via whole-word recognition, previously stored telephone numbers can be dialled by simply stating the name of the person you wish to call and, if the telephone pre-wiring option is

fitted, you can even have your text messages read out to you. There's also a CD/DVD changer with MP3 playback; space for up to 6 GB of music on the system's hard drive; a Media Interface for connection and operation of iPod® and USB media; and a Bluetooth® facility for safe hands-free mobile calls is included on all C-Class audio systems.

¹COMAND is standard on Executive SE but without the 6-disc changer and Media Interface



The controller: the armrest is designed in such a way that your hand lies naturally on the COMAND controller, via which the system's many functions can be operated quickly, easily and intuitively



Takes the rough with the smooth – so that you don't have to

Agility Control Suspension with Adaptive Damping System

Mercedes-Benz has always been renowned for its ride comfort. And with the C-Class, our suspension engineers have surpassed themselves once more. Its Adaptive Damping System, which comes as part of the standard Agility Control Suspension, automatically adjusts the damper settings at each wheel. It provides a firmer or softer ride depending on the situation or surface, and smoothes imperfections more effectively than conventional steel suspension.

The low noise levels inside the cabin further enhance your sense of well-being. By fine-tuning, insulating and sealing countless bodywork details, we've succeeded in ensuring wind noise is kept at bay more effectively than ever.

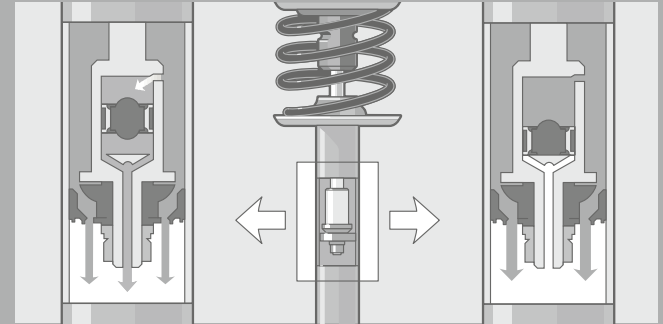

The Adaptive Damping System: in normal driving, the system uses softer damper settings to ensure a highly comfortable ride; in sportier driving, it switches to firmer settings for optimum stability



Space to accommodate all your needs

The C-Class Estate's intelligently designed load compartment

Every day brings a new set of challenges – be it at work, at home or elsewhere. With the C-Class Estate, you're equipped for whatever comes your way. The load compartment is designed to cope with all kinds of cargo, offering a class-leading luggage space from 910 to 1,500 litres – 485 litres with the seats in place – and a range of practical features such as side luggage nets and the optional Easy-Pack load-securing kit. Other clever touches include an Easy-Pack tailgate, which comes as standard. It opens and closes automatically at the touch of a button.

The C-Class Estate handles heavier cargo with equal aplomb – thanks to a payload capacity of 530 kg,¹ a self-levelling suspension option and a towing capacity up to 1,800 kg. The trailer stabilisation function incorporated into the Electronic Stability Programme (ESP®) is a further plus when towing, while the optional tow bar itself features a pivot mechanism that allows it to be tucked away when not in use.

¹Measured according to DIN standard







Intelligent thinking can be a life-saver

The integral safety concept from Mercedes-Benz

Few things are more important to us than the pursuit of new safety technologies. We've been developing innovative safety concepts since as far back as the 1950s, when legendary Mercedes-Benz engineer Béla Barényi invented the very first safety cell. At the same time, Barényi's colleagues were coming up with ground-breaking ideas of their own. One of them, Rolf Maier, devised a simple way of testing the behaviour of the steering and restraint systems during a crash.

He and his fellow engineers designed a special sled to be driven against a wall at high speed. For impact absorption purposes, they hit upon another ingenious solution: gherkin tins from the factory canteen. It's a classic example of the creativity that shaped those pioneering years.

As much as we enjoy looking back, we never stop looking forward – and nothing illustrates this better than our vision of accident-free driving. With our integral safety concept, we are now closer to realising this vision than ever before. It's a concept that divides safety into three distinct phases. The first phase is helping the driver to recognise and deal with critical situations that arise during the journey. The second phase is immediately prior to a potential accident, when the car can take various preventative measures to help reduce the risk of injury. Then, during an accident itself, passive safety measures can ensure effective protection of the individual occupants. And there's another vital point: following an accident, a Mercedes is designed to make passenger rescue as easy as possible.



There's only one thing better than an alert driver. An alert Mercedes driver

Built for safety right from the start

The beginnings of an accident often come long before any impact. Inattentiveness, impaired visibility or unforeseen danger are the root causes of many a crash. That's why the C-Class helps you concentrate fully on the road – and cope with any critical situations you encounter along the way. With Bluetooth® hands-free capability, a multi-function steering wheel as standard and Linguatronic voice control included with the optional Audio 50 or COMAND multimedia system, it even lets you operate a range of features and functions without taking your hands off the wheel. In addition, the C-Class is lavishly equipped with electronic aids that assist you during the journey and alert you to potential dangers. These include the tyre pressure loss warning system, the Electronic Stability Programme (ESP®), Brake Assist (BAS) and, a first for the C-Class, ESP® trailer stabilisation. The ESP® and BAS sensors can

detect critical situations – such as heavy oversteer or understeer, sharp steering movements, panic braking or emergency stops – and provide just the assistance the situation requires.

You can also equip your C-Class with the optional Intelligent Light System. It automatically adapts the dipped-beam lights in its bi-xenon headlamps to the given driving situation, illuminating a wider area when driving on country roads and improving long-range visibility on motorways. The system also includes enhanced fog lamps that significantly improve illumination of the nearside of the road, as well as the cornering light function and Active Light System, which enables the headlamps to follow your steering inputs for better visibility in bends.

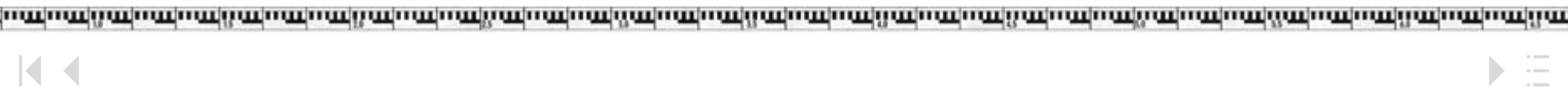

In critical situations, every second is precious

The Pre-Safe® anticipatory safety system

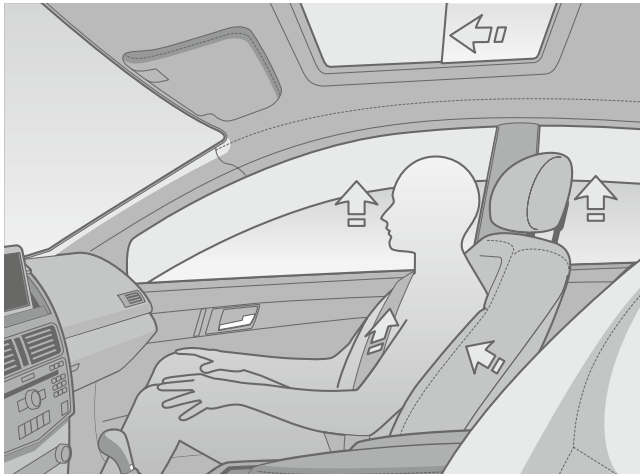

Until 2002, the final seconds before an impact had gone largely unused. Then Mercedes-Benz introduced the Pre-Safe® system. Now fitted to the C-Class as standard, the Pre-Safe® system makes the most of that time, initiating a range of measures that enhance occupant protection should the collision prove unavoidable.

The Pre-Safe® system: if a potential accident is imminent, the Pre-Safe® system can trigger the seat belt pre-tensioners, close the side windows and electric sunroof (if fitted) and move the front passenger seat to a more favourable position (if fitted with Memory Package)



The Pre-Safe® system works with the ESP® and BAS sensors to recognise and react to danger. If the sensors detect a potentially critical driving situation, Pre-Safe® assesses the information and, if necessary, implements anticipatory measures to help protect the occupants. These include automatically activating the seat belt tensioners, moving the front passenger seat to a more favourable position (if fitted with Memory Package) and closing the side windows and electric sunroof (if fitted).

The C-Class also comes with adaptive brake lights as standard. If the driver applies the brakes suddenly and forcefully, they automatically start flashing, providing a clearer warning to those behind.

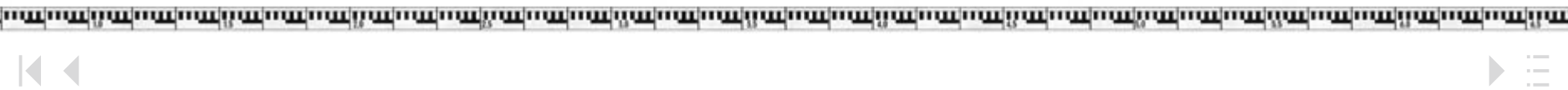

However hard the knock, your C-Class will cushion the blow

Effective protection via restraint systems and safety cell

The many occupant protection systems on board the C-Class help to significantly reduce the risk of injury in accidents. Even the head restraints feature intelligent safety technology. If the sensors detect a rear-end collision, the Neck-Pro front head restraints move upwards and forwards within milliseconds, helping to support the head sooner and lessen the likelihood of whiplash injuries.

Seat belt pre-tensioners for the front and outside rear seats are also fitted as standard, as is a comprehensive airbag system, including a driver kneebag, dual-stage airbags for driver and front passenger, and windowbags that cover practically the entire window area on each side.

A wide range of sensors ensures the airbags work as effectively as possible. The occupant classification system allows the front passenger restraint systems to be deployed according to his or her needs, while the sidebags and windowbags benefit from air pressure sensors in the side doors. In a side-on collision, these sensors can detect pressure changes caused by deformation and the airbag control unit can then inflate the sidebags and windowbags as required. With such extensive occupant protection, it's no wonder that the C-Class received a 5-star Euro NCAP rating. The C-Class helps to look after other road users too. The bodywork's smooth surfaces and deformation characteristics are designed to minimise pedestrian injury in the event of an impact.



Even when stranded, the C-Class still comes to your aid

Greater post-crash safety and easier rescue

After an accident, the C-Class can take a variety of measures designed to reduce the knock-on effects of a collision and facilitate the work of the emergency services. Depending on the type and severity of the impact, these can include automatically switching off the engine and cutting off the fuel supply, turning on the hazard warning lights and emergency cabin lighting, lowering the side windows slightly if necessary, and automatically unlocking the central locking. A special rescue guide developed by Mercedes-Benz for emergency services around the world completes our comprehensive safety concept.





Passion and precision – the essence of AMG

Mercedes-AMG: racing technology for the road

“One man, one engine” – that’s the golden rule at AMG’s Affalterbach plant. From fitting the crankshaft to adding the oil, the entire engine assembly is in the hands of one highly skilled professional. It’s a highly personal approach and one that ensures all AMG engines meet the very highest standards of quality and reliability. And just so you know who to thank, each one bears a metal plaque with its creator’s signature.

This kind of dedication and attention to detail has been a hallmark of AMG for over four decades, ever since founders Hans Werner Aufrecht and Erhard Melcher began building racing Mercedes – and applying their expertise to road-going models. Today, over 40 years on, AMG continues to bring racing technology to the road – with cars such as the breathtaking C 63 AMG.



The sportiest C-Class of all time

The C 63 AMG

6.2 litres, 457 hp (336kW), 600Nm, 0 to 62 mph in 4.5 (Saloon) or 4.6 seconds (Estate) – the C 63 AMG turns in a truly remarkable set of figures. And yet it's even more impressive on the road. That's because its drivetrain, chassis and braking systems all work together to give you maximum driving pleasure.

The AMG Speedshift Plus 7G-Tronic transmission transfers power smoothly and effectively to the wheels, while also enhancing driving enjoyment thanks to rapid downshifts and a stability-enhancing throttle-blip function. The speed-sensitive AMG sports steering, combined with AMG sports suspension featuring a wider front track, helps you exploit the naturally aspirated AMG V8 to the full. And the AMG high-performance braking system and three-stage Electronic Stability

Programme ESP® ensure that power is always kept firmly under control. Perhaps most impressively of all, the C 63 AMG combines this exhilarating speed and agility with exceptional comfort, safety and practicality – making it a high-performance sports car you can enjoy every single day.





You've never seen a C-Class like it

One look at the C 63 AMG and you'll know this is no ordinary C-Class. The ridged bonnet and special AMG radiator grille with central three-pointed star and twin chromed louvres make for an unmistakable front end, while flared front wings and fog lamps situated at the far sides of the front apron further underline the broad and muscular look. There are also purposeful-looking side vents on the apron's outer edges - they draw heat away from the additional oil cooler - and the dark-tinted lenses of the bi-xenon headlamps. The side view is dominated by the 18" AMG alloy wheels in Titanium Silver with high-shine finish, and also features AMG side skirts plus stylish '6.3 AMG' badges on the wings. The rear is equally striking, thanks to its AMG apron, black diffuser, LED tail lights, four chromed tailpipes and an AMG spoiler that helps to reduce lift.

For an even more exclusive look, the AMG Performance Studio offers options such as an AMG Performance Package Plus, 19" multi-spoke AMG alloy wheels in Titanium Grey and AMG carbon-fibre trim.





Unmistakable even from the inside

Even the cabin of the C 63 AMG is instantly recognisable – thanks in particular to the AMG sports seats with integral head restraints and adaptive backrests. Together with the flat-bottomed three-spoke AMG sports steering wheel with race-style gear shift paddles and the AMG instrument cluster, they lend the cockpit a truly sporty look and feel.

The seats are upholstered in nappa leather, which comes in Black, Alpaca Grey or Sahara Beige, with matching nappa leather for the door centre panels and door armrests. Standard AMG door sills, aluminium trim and a black roof lining complete the eye-catching AMG treatment.





TITANE





My C-Class





Four flavours of C-Class

SE, Executive SE, Elegance and Sport

With its many intelligent technologies, the C-Class adapts to your individual needs. What's more, it caters for your individual tastes too, offering a wide range of options and

a choice of three different lines. Each has its own distinct character and style. SE, Executive SE, Elegance or Sport: which is the C-Class for you?



The C-Class Saloon SE

The front of the C-Class Saloon SE bears the traditional hallmarks of a Mercedes-Benz: a chromed grille with laurel wreath badge and a three-pointed star that sits proudly on the bonnet. There's also chrome around the top edge of the side windows. Three black louvres,



Chromed and black trim elements at the front of the C-Class SE

meanwhile, help to emphasise the front air intakes and the front fog lamp surrounds are in matching black.

All SE models are fitted with attractive 16" 7-spoke alloy wheels as standard.



At the rear, the matt black handle identifies the SE line



The C-Class Estate SE

The C-Class Estate SE combines classic looks and class-leading practicality. Like its Saloon counterpart, it features a front end that's modern, refined and unmistakably Mercedes. The radiator grille is chrome-trimmed and embellished with the traditional laurel wreath badge; above it, a three-pointed star rises from the bonnet in time-honoured fashion. Black finishes for the front air intakes and fog lamp surrounds complement the SE's understated style, while the tailgate handle and roof rails are also finished in black.

Chrome strips around the side windows provide a gleaming contrast to the black detailing, and there are attractive alloy wheels as standard on all SE models.



The spacious and attractively finished load compartment



The SE interior

The SE's refined style continues in the cabin. Its cross-stitched seats wear Brighton cloth – in Black combined with either Black, Alpaca Grey, Beige or Red – or optional Artico artificial leather. There's also fine chrome detailing and subtle High-Gloss Black trim as standard, with Burr Walnut wood trim available as an option.



The many chrome details blend harmoniously with the High-Gloss Black trim

Standard equipment includes the Audio 20 radio with single CD player and MP3 playback, a Bluetooth® interface for hands-free telephony, Parktronic, front and rear, two-zone automatic climate control and leather trim for multi-function steering wheel and gear shift lever.



Comfortable, attractive, and with ample space for all: the SE line's rear seats



C-Class Executive SE

Available in Saloon and Estate, the C-Class Executive SE offers a choice of refined and economical engines, allied to either 6-speed manual (C 180 KOMPRESSION BlueEFFICIENCY, C 200 CDI BlueEFFICIENCY and C 220 CDI BlueEFFICIENCY¹) or 5-speed automatic transmission (C 180 CGI BlueEFFICIENCY, C 200 CDI BlueEFFICIENCY and C 220 CDI BlueEFFICIENCY). Thanks to energy-saving BlueEFFICIENCY measures, all three variants

achieve impressively low fuel consumption and CO₂ emissions, thereby helping to further reduce your running costs.

Both Saloon and Estate boast exclusive 16" 7-spoke alloy wheels and eye-catching exterior details such as a polished stainless steel tailpipe and a chromed boot lid or tailgate handle, while the Estate's Easy-Pack powered tailgate ensures hassle-free access to the large load compartment.

Inside, the Executive SE is exceptionally comfortable and generously equipped, with seats in Brighton cloth upholstery (electrically adjustable for height and tilt), High-Gloss Black trim for the doors and centre console, and a leather-trimmed 12-button multi-function steering wheel.

¹Saloon only



Chromed exhaust tip



Chromed tailgate handle



16" 7-spoke alloy wheels

Also fitted as standard is our COMAND multimedia system along with a 7-inch central display. COMAND comprises audio features such as a radio, an MP3-compatible CD player and a 6 GB music register as well as a hard drive-based map navigation system. In addition, it comes with a Bluetooth® interface for hands-free telephony, Linguatronic voice control and an aux-in socket in the glove compartment, and can be combined with a variety of options,

including a 6-disc CD changer, a DAB digital radio and a Media Interface for integrating external devices, such as iPod®.



Multi-function steering wheel



COMAND multimedia system



The Estate's large load compartment

The C-Class Saloon Elegance

Your first glimpse of the C-Class Elegance is a moment to savour. Let your gaze linger on the bonnet-mounted three-pointed star and prominent grille. Take in the chrome-trimmed fog lamp surrounds and bumpers.



The Elegance front end features stylish chrome details

Then follow the chrome trim around the sides and to the rear, where the boot lid handle is also finished in chrome. The aluminium shoulder line trim and 16" 12-spoke alloy wheels beautifully complement the chrome detailing.



At the rear, the chrome highlights extend to the boot lid handle and bumper strips



The C-Class Estate Elegance

The C-Class Estate Elegance combines chrome and aluminium to eye-catching effect. In addition to the Saloon's aluminium shoulder line trim and numerous chrome highlights, the Estate features polished aluminium roof rails and a chromed tailgate handle – plus, of course, a spacious load compartment that's finished in attractive, high-quality materials.



Practical, spacious and beautifully finished: the Elegance load compartment



The Elegance interior

Inside, the Elegance seats are upholstered in luxurious Artico artificial leather and come in a choice of colours.

A leather-trimmed multi-function steering wheel and Eucalyptus or optional Burr Walnut wood trim further add to the air of sophistication, while the generous standard

equipment includes the Audio 20 radio/single CD player, Bluetooth® hands-free facility and two-zone automatic climate control. The Elegance driver also benefits from the comfort and convenience of standard rain-sensing wipers, electrically folding door mirrors and auto-dimming driver's door and rear-view mirrors.



Optional Alpaca Grey leather makes the C-Class seats even more inviting



Eucalyptus wood trim adds distinguished character to the Elegance interior



The C-Class Saloon Sport

The Sport line lends the C-Class Saloon an even more eye-catching look. The wide grille with its large three-pointed star and chrome-edged louvres ensures Sport models are instantly recognisable, while the standard AMG bodystyling and 17" AMG 6-twin-spoke alloy wheels make for a truly muscular stance. What's more, Sport models not only look more dynamic,



The Sport line's front end has a striking and dynamic look

they feel it too, thanks to sports suspension that's 15 mm lower than on other models, speed-sensitive parameter steering with a more direct steering ratio, and a sports braking system with larger, cross-drilled brake discs front and rear. The brake calipers feature 'Mercedes-Benz' lettering and there's also a sports exhaust system on petrol models.



Firmly grounded: the sports suspension is 15 mm lower on the Sport



The C-Class Estate Sport

With its special Sport line grille, AMG aprons and side skirts, and 17" AMG 6-twin-spoke alloy wheels, the C-Class Estate Sport is one of the most dynamic-looking load-carriers around.

It's one of the most entertaining too. With the same lowered sports suspension, speed-sensitive parameter steering and cross-drilled brake discs as the Sport line Saloon, it's an Estate that's as satisfying to drive as it is to load up.



Inside the load compartment of the Sport



The Sport interior

Inside the Sport line's cabin, highly supportive sports seats set the tone. They are upholstered in a choice of Black or Alpaca Grey Liverpool cloth and Artico artificial leather, and are complemented by finely textured aluminium trim. Full leather upholstery and Black Bird's-Eye Maple wood trim are both available as options. Brushed stainless steel sports pedals, black floor mats with 'AMG' lettering, black roof lining and an aluminium-

look shift lever further enhance the sporty cabin ambience. There's also a nappa leather-trimmed 3-spoke sports steering wheel – with steering wheel gear shift paddles on automatic transmission models. The instrument cluster looks very similar to that of the C 63 AMG with its 3D tube dials – a look borrowed from the world of motor sport.



Star performer: the nappa leather-trimmed 3-spoke sports steering wheel with gear shift paddles (automatic transmission only)



The studded stainless steel sports pedals combine design and function



	SE	Executive SE	Elegance	Sport
Exterior				
B-pillar trim	Matt Black	Matt Black	Gloss Black	Gloss Black
Boot lid handle	Matt Black	Chrome	Chrome	Chrome
Bumpers and side panels	Body colour	Body colour	Body colour with chrome trim	Body colour with chrome trim
Fog lamp surrounds	Black	Black	Chrome	Chrome
Line badge	-	-	Elegance badge	-
Radiator grille	Chrome, with three louvres, in Matt Grey trim, three-pointed star on bonnet	Chrome, with three louvres, in Matt Brilliant Silver trim, three-pointed star in grille	Chrome, with three louvres, in Atlas Grey metallic trim, three-pointed star on bonnet	Chrome, with three louvres, in Matt Brilliant Silver trim, three-pointed star in grille
Shoulder line trim strip	Matt Black	Matt Black	Polished aluminium	Polished aluminium
Wheels	16" 7-spoke alloy wheels	16" 7-spoke alloy wheels	16" 12-spoke alloy wheels (17" 12-spoke alloy wheels for C 350 and C 350 CDI)	17" AMG 6-twin-spoke alloy wheels
Interior				
Instrument cluster	Black backplate	Black backplate	Black backplate	Titanium Silver backplate
Interior trim	High-Gloss Black	High-Gloss Black	Eucalyptus wood	Aluminium
Seat trim	Brighton cloth	Brighton cloth	Artico artificial leather	Liverpool cloth/Artico artificial leather ¹
Shift lever console	Synthetic gaiter trim, black surround	Synthetic gaiter trim, black surround	Leather gaiter trim, chrome surround	Leather gaiter trim, chrome surround
Steering wheel	Multi-function steering wheel (4-button), leather-trimmed, 4-spoke design	Multi-function steering wheel (12-button), leather-trimmed, 3-spoke design, with trip computer	Multi-function steering wheel (12-button), leather-trimmed, with 4.5-inch display in instrument cluster	Multi-function steering wheel (12-button), nappa leather-trimmed, 3-spoke design, with gear shift paddles (auto only) and 4.5-inch display in instrument cluster

¹On Sport line, seat side bolsters are in Artico



Standard equipment for Saloon (selection)

3-point seat belts and head restraints for all seats

6-speed manual transmission with Hill Start Assist¹

Adaptive Brake System with brake drying and priming

Adaptive brake lights

Agility Control Suspension with Adaptive Damping System

Airbags, driver and front passenger, with dual-stage deployment sensors, plus front sidebags, windowbags and driver kneebag

AMG bodystyling including front and rear aprons and side skirts (Sport only)

Anti-lock braking system (ABS) with Brake Assist (BAS)

Audio 20 radio with single CD drive (MP3 compatible), 8 speakers, 5-inch colour display and central controller dial (SE, Elegance and Sport)

Automatic climate control – two-zone

COMAND multimedia system, navigation system, with single CD drive (Executive SE only)

Electric windows (4), including remote control operation and one-touch function all round

Electronic Stability Programme (ESP®) with Acceleration Skid Control (ASR)



Two-zone automatic climate control

Front fog lamps with clear lenses

Front seats with electric height and backrest-angle adjustment

Headlamp Assist – automatic headlamp function

ISOFIX child seat fitments in rear (outer seats only)

Leather-trimmed multi-function steering wheel with trip computer

Lowered sports suspension, by 15 mm (Sport only)

Outside temperature display

Parameter steering – speed-sensitive power steering (Sport only)

Parktronic – front and rear

Pre-Safe® anticipatory safety system

Rain-sensing wipers

Remote boot lid release from key

Seat belt pre-tensioners with belt force limiters for front and outside rear seats

Service interval indicator ASSYST



Designer key

¹With ECO start/stop on C 180 CGI BlueEFFICIENCY; 5-speed automatic on C 250 CGI; C 350 CDI and C 350 have 7G-Tronic 7-speed automatic transmission as standard



High style all round

Alloy wheel designs for your C-Class

The C-Class SE comes with 16" 7-spoke alloy wheels as standard. The Elegance offers either 16" or 17" 12-spoke wheels as standard, depending on the model. The Sport has 17" AMG 6-twin-spoke alloys that emphasise its dynamic looks. As an option, all lines can be specified with alternative wheel designs - the SE and Elegance with 16" 7-spoke, 17" multi-spoke or 17" 5-spoke alloy wheels, the Sport with 18" AMG 5-twin-spoke alloys. All C-Class alloy wheels are finished in Titanium Silver, the AMG alloy wheels in burnished Titanium Silver.



16" 7-spoke alloy wheels (standard on SE, optional on Executive SE)



16" 7-spoke alloy wheels (standard on Executive SE)



16" 12-spoke alloy wheels (standard on Elegance, excluding C 350 and C 350 CDI)



17" 12-spoke alloy wheels (standard on Elegance, C 350 and C 350 CDI only)



16" 7-spoke alloy wheels (optional on SE, Executive SE and Elegance)



17" 5-spoke alloy wheels (optional on SE, Executive SE and Elegance)



17" 7-twin-spoke alloy wheels (optional on SE, Executive SE and Elegance)



17" multi-spoke alloy wheels (optional on SE, Executive SE and Elegance)

Sporting perfection

AMG alloy wheels

The Sport line features exclusive AMG alloy wheels, with a choice of burnished 17" and 18" designs. The standard 17" wheels are fitted with 225/45 tyres at the front and

245/40s at the rear, while the 18" AMG 5-twin-spoke wheels wear 225/40s and 255/35s respectively.



17" AMG 6-twin-spoke alloy wheels (standard on Sport)



18" AMG 5-twin-spoke alloy wheels (optional on Sport)

Exclusivity in alloy

incenio design wheels



For an even more customised look, talk to your Mercedes-Benz Retailer. They can fit your C-Class with incenio design alloy wheels: for instance, the 17" incenio 'Naantali' 5-Y-spoke design shown here.¹

incenio 'Naantali' 5-Y-spoke design alloy wheel, size 225/45 R 17 (Retailer-fit accessory)¹

¹For availability of Retailer-fit accessory alloy wheels, please check with your local Mercedes-Benz Retailer



Even travel news sounds a treat

In-car entertainment and navigation

Driving enjoyment isn't the only pleasure a C-Class has to offer. Listening enjoyment is guaranteed too, thanks to a range of high-quality audio systems. The standard Audio 20 radio includes a 5-inch colour display, Bluetooth® mobile phone connectivity and a CD player that can read MP3 files. An integrated 6-disc CD changer can be added as an option.

The optional Audio 50 radio adds DVD-based navigation with TMC (Traffic Message Channel), an integrated audio CD/DVD changer and Linguatronic voice control, while the COMAND option¹ provides even

more features, combining entertainment, navigation and communication in one easy-to-use system. You'll find more information about COMAND on page 28. All three audio systems can be combined with the optional Harman Kardon® Logic 7® surround sound system. With a 9-channel DSP amplifier delivering a total of 450 W, twelve high-performance speakers and Dolby Digital 5.1 (Audio 50 and COMAND systems only, both include Media Interface to connect mobile media devices; the DAB radio is available as an option), it offers an unsurpassed listening experience.

¹Standard on Executive SE



Audio 20 radio and CD player with MP3 compatibility



Audio 50 radio and DVD-based navigation system with audio CD/DVD changer



	C 200 CDI BlueEFFICIENCY	C 220 CDI BlueEFFICIENCY	C 250 CDI BlueEFFICIENCY	C 350 CDI BlueEFFICIENCY	C 180 KOMPRESSOR BlueEFFICIENCY	C 180 CGI BlueEFFICIENCY	C 250 CGI BlueEFFICIENCY	C 350	C 63 AMG
Optional extras for Saloon¹ (selection)									
5-speed automatic transmission	○	○	○	-	-	○	●	-	-
7G-Tronic 7-speed automatic transmission	-	-	-	● ²	-	-	-	● ²	● ³
Automatically dimming rear-view mirror and driver's door mirror (standard on Elegance and Sport)	○	○	○	○	○	○	○	○	●
Bi-xenon headlamps with cornering light function and LED rear indicators	○	○	○	○	○	○	○	○	●
Burr Walnut wood trim (SE and Elegance only)	○	○	○	○	○	○	○	○	-
COMAND multimedia system with integrated 6-disc CD/DVD changer and Media Interface ⁴	○	○	○	○	○	○	○	○	○
Cruise control (std. with auto. transmission)	○	○	○	●	○	○	●	●	●
DAB digital radio tuner	○	○	○	○	○	○	○	○	○
Dynamic Handling Package with sport mode (Sport only)	-	○	-	○	-	-	○	○	-

● Standard ○ Optional extra - Not available ¹Some items may only be available in conjunction with other options. Please check with your local Mercedes-Benz Retailer ²Only standard on Elegance and Sport
³AMG Speedshift Plus 7G-Tronic ⁴Cables included for aux-in, USB or iPod® connectivity. Standard on Executive SE but without the 6-disc changer and Media Interface



The LED display for the Parktronic front and rear parking aid



Electric roller blind for the rear windscreen

	C 200 CDI BlueEFFICIENCY	C 220 CDI BlueEFFICIENCY	C 250 CDI BlueEFFICIENCY	C 350 CDI BlueEFFICIENCY	C 180 KOMPRESSOR BlueEFFICIENCY	C 180 CGI BlueEFFICIENCY	C 250 CGI BlueEFFICIENCY	C 350	C 63 AMG
Optional extras for Saloon¹ (selection)									
Electric glass sunroof – tilting and sliding	○	○	○	○	○	○	○	○	●
Electric rear roller blind	○	○	○	○	○	○	○	○	○
Harman Kardon® Logic7® surround sound system	○	○	○	○	○	○	○	○	○
Heated front seats	○	○	○	○	○	○	○	○	●
Intelligent Light System with bi-xenon headlamps, cornering light function and LED daytime running lights	○	○	○	○	○	○	○	○	○ ²
Leather upholstery (Elegance and Sport only)	○	○	○	○	○	○	○	○	● ³
Luxury automatic climate control – three-zone with rear digital display	○	○	○	○	○	○	○	○	○
Memory function for driver's seat, steering column and exterior mirrors	○	○	○	○	○	○	○	○	●



The Intelligent Light System includes bi-xenon headlamps and active cornering light function



Rear control panel for three-zone luxury automatic climate control

	C 200 CDI BlueEFFICIENCY	C 220 CDI BlueEFFICIENCY	C 250 CDI BlueEFFICIENCY	C 350 CDI BlueEFFICIENCY	C 180 KOMPRESSOR BlueEFFICIENCY	C 180 CGI BlueEFFICIENCY	C 250 CGI BlueEFFICIENCY	C 350	C 63 AMG
Optional extras for Saloon¹ (selection)									
Metallic paint	○	○	○	○	○	○	○	○	●
Multi-contour front seats ⁴	○	○	○	○	○	○	○	○	-
Panoramic glass sunroof with electric sun blinds	○	○	○	○	○	○	○	○	-
Parameter steering – speed-sensitive power steering (standard on Sport)	○	○	○	○	○	○	○	○	● ⁵
Sidebags in rear	○	○	○	○	○	○	○	○	○
Split/folding rear seats including through-loading facility	○	○	○	○	○	○	○	○	●
Telephone pre-wiring with hands-free facility	○	○	○	○	○	○	○	○	○
Tow bar with trailer stabilisation ⁴	○	○	○	○	○	○	○	○	-

● Standard ○ Optional extra - Not available ¹Some items may only be available in conjunction with other options. Please check with your local Mercedes-Benz Retailer ²Bi-xenon headlamps standard on C 63 AMG
³AMG nappa leather ⁴Only available on SE and Elegance ⁵Sports power steering



Rear armrest with cup holders

Standard equipment for Estate (selection)

 3-point seat belts and head restraints for all seats

 6-speed manual transmission with Hill Start Assist¹

 16" alloy wheels – 7-spoke design (SE)

 Adaptive Brake System with brake drying and priming

 Adaptive brake lights

 Agility Control Package with Adaptive Damping System

 Airbags, driver and front passenger, with dual-stage deployment sensors, plus front sidebags, windowbags and driver kneebag

 AMG bodystyling including front and rear aprons and side skirts (Sport only)

 Anti-lock braking system (ABS) with Brake Assist (BAS)

 Audio 20 radio with single CD drive (MP3 compatible), 8 speakers, 5-inch colour display and central controller dial (SE, Elegance and Sport)

 Automatic climate control – two-zone

 Chrome load-securing rings and side luggage nets



Easy-Pack automatic powered tailgate

 Clear-lens headlamps with projection beams

 Easy-Pack automatic powered tailgate

 Electric windows (4), including remote control operation and one-touch function all round

 Electronic Stability Programme (ESP®) with Acceleration Skid Control (ASR)

 Front fog lamps with clear lenses

 Front seats with electric height and backrest-angle adjustment and front armrest

 Headlamp Assist – automatic headlamp function

 ISOFIX child seat fitments in rear (outer seats only)

 Leather-trimmed multi-function steering wheel with trip computer

 Lowered sports suspension, by 15 mm (Sport only)

 Outside temperature gauge

 Parameter steering – speed-sensitive power steering (Sport only)

 Parktronic – front and rear

 Pre-Safe® anticipatory safety system

 Seat belt pre-tensioners with belt force limiters for front and outside rear seats

 Split folding rear seats 1/3:2/3

¹ C 350 CDI BlueEFFICIENCY and C 350 have 7G-Tronic 7-speed automatic transmission as standard

	C 200 CDI BlueEFFICIENCY	C 220 CDI BlueEFFICIENCY	C 250 CDI BlueEFFICIENCY	C 350 CDI BlueEFFICIENCY	C 180 KOMPRESSOR BlueEFFICIENCY	C 180 CGI BlueEFFICIENCY	C 250 CGI BlueEFFICIENCY	C 350	C 63 AMG
Optional extras for Estate¹ (selection)									
5-speed automatic transmission	○	○	○	-	-	○	●	-	-
7G-Tronic 7-speed automatic transmission	-	-	-	● ²	-	-	-	● ²	● ³
Dynamic Handling Package (Sport only)	-	○	○	○	-	-	○	○	-
COMAND multimedia system ⁴	○	○	○	○	○	○	○	○	○
Easy-Pack load-securing kit	○	○	○	○	○	○	○	○	○
Integrated child seats (including lateral support headrest)	○	○	○	○	○	○	○	○	-
Panoramic glass sunroof	○	○	○	○	○	○	○	○	-
Privacy glass – includes side windows rear of B-pillar and rear windscreen	○	○	○	○	○	○	○	○	○
Roller sun blinds in the rear doors	○	○	○	○	○	○	○	○	○
Self-levelling rear suspension (not available on Sport)	○	○	○	○	○	○	○	○	-
Tow bar with trailer stabilisation	○	○	○	○	○	○	○	○	-

● Standard ○ Optional extra - Not available

¹ Some items may only be available in conjunction with other options. Please check with your local Mercedes-Benz Retailer

² Only on Elegance and Sport

³ AMG Speedshift Plus

⁴ Cables included for aux-in, USB or iPod[®] connectivity. Standard on Executive SE but without the 6-disc changer and Media Interface



Integrated child seat (optional, Estate only)

Panoramic glass sunroof with electric roller blinds (optional)

Where the extras are stars too

Retailer-fit accessories for the C-Class Saloon

Can't get enough of the C-Class? With our Retailer-fit accessory range you can give it an even sportier style, add extra practicality, or tailor the cabin to your individual needs. The styling options include front and rear aprons, roof and boot-lid rear spoilers, and incenio design alloy



Touch of luxury: the wood-trimmed steering wheel

wheels. There's a range of carrying systems to choose from, and the interior accessories include everything from wood and leather steering wheels to additional cup holders. For more details, talk to your Mercedes-Benz Retailer or pick up a copy of our accessories brochure.



Coffee to go: twin cup holders for the centre console



Equipped to meet every need

Retailer-fit accessories for the C-Class Estate

Practicality and style is what the C-Class Estate is all about. And with Retailer-fit accessories, you can have even more of both. You can also select extras to suit your particular lifestyle. Keen cyclists, for instance, will appreciate the new Alustyle bicycle rack, while the aesthetic and aerodynamic roof box is ideal for carrying



Alustyle roof bars with new Alustyle bicycle rack

long loads such as skis. There's a variety of practical extras for inside the car too.

The non-slip, food-safe boot liner is designed specifically for the C-Class Estate load compartment, while the twin concertina bags are the perfect way to transport your shopping.



Twin concertina bags with practical carrying handles

Made from washable, hard-wearing nylon, each bag has two large sections and can be lifted in and out with ease.

For more details about these and other useful items, consult your Mercedes-Benz Retailer or see our separate accessories brochure.



The non-slip boot liner



Proof that beauty doesn't have to be short-lived

A more scratch-resistant clearcoat for longer-lasting protection

Things of beauty require extra-special care. Which is why the C-Class is protected by one of the most advanced clearcoats on the market. Developed by Mercedes-Benz, it has a denser molecular structure than conventional clearcoats, making it more resistant to scratches, chemicals and mechanical stresses – such as those exerted by automatic car washes – and less sensitive

to sunlight, rain and other environmental factors. As a result, this special coating helps your C-Class to retain both its handsome looks and its long-term value, while also lending a deeper and longer-lasting shine. It means whichever finish you choose, you can be sure your C-Class will stay beautiful for many years to come.



There's more to the C-Class paintwork than meets the eye. Because beneath that lustrous finish lies a comprehensive anti-corrosion system. Thanks to technologies such as zinc phosphate treatment and electrocoating, the longevity of your car's bodywork is guaranteed. In addition, coatings are mostly water-based in order to reduce environmental impact.

NON-METALLIC PAINTS



040 Black



590 Fire Opal

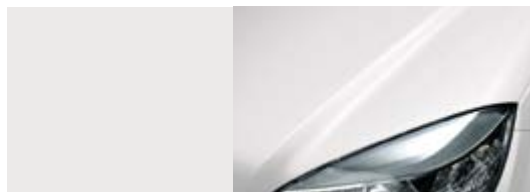

650 Calcite White

METALLIC PAINTS



197 Obsidian Black



230 Indigolite Blue



359 Tansanite Blue



497 Cuprite Brown

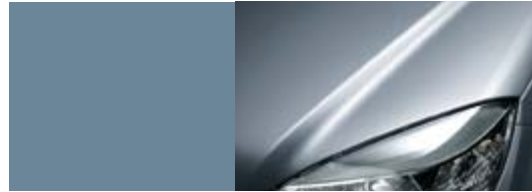

792 Palladium Silver



755 Tenorite Grey



794 Pearl Beige



775 Iridium Silver

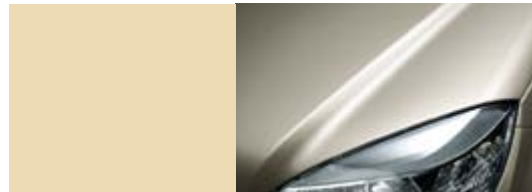

798 Sanidine Beige

Mercedes-Benz seats offer exceptionally high levels of comfort. The springs are tailored to the needs of the vehicle and the firmness of the cushioning is chosen accordingly, ensuring optimum vibration and shock absorption. In addition, the use of separate foam sections for seat base and side bolsters increases comfort even further.

The finishing touch comes courtesy of your choice of upholstery. For the C-Class, there's a range of fabrics designed to perfectly complement each of the C-Class lines.

SE/EXECUTIVE SE

Brighton cloth¹



001 Black



018 Alpaca Grey

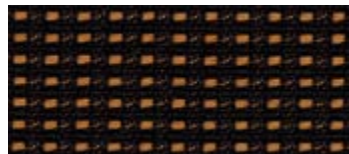

055 Black/Beige



057 Black/Red

ELEGANCE

Artico artificial leather²

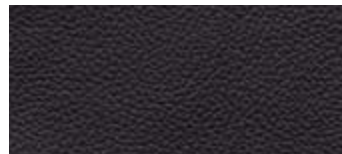

101 Black

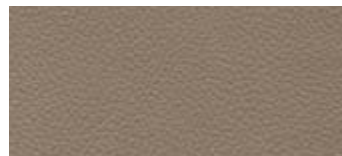

115 Almond Beige



118 Alpaca Grey

SPORT

Liverpool cloth/Artico artificial leather^{2,3,4}

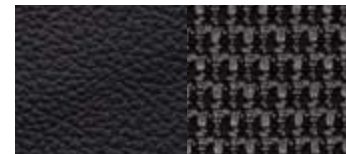

701 Black

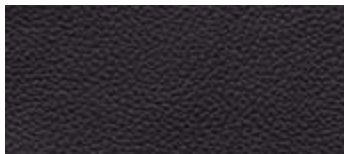

718 Alpaca Grey

SE/EXECUTIVE SEArtico^{2,3} artificial leather (optional)

101 Black



118 Alpaca Grey

ELEGANCE AND SPORT⁵

Leather (optional)

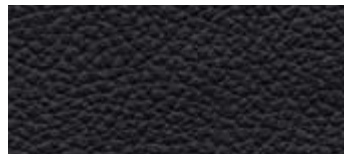

201 Black

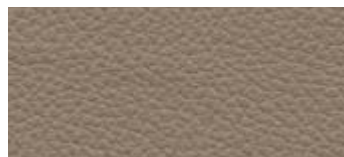

215 Almond Beige (Elegance only)



218 Alpaca Grey

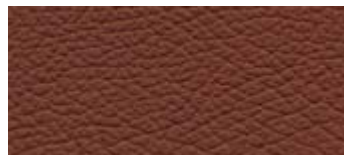

207 Cognac (Sport only)

C 63 AMG

Nappa leather

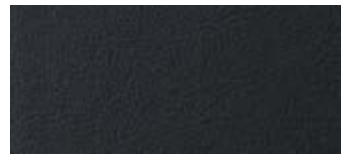

201 Black

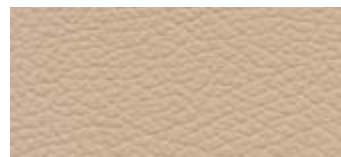

205 Sahara Beige

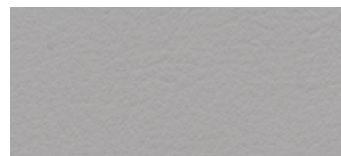

218 Alpaca Grey

¹ For seat centre upholstery and door panels; see images on page 56

² Seat centre panels are perforated

³ For seat upholstery see images on page 71

⁴ Side bolsters in Artico, centre seat panels in cloth as shown

⁵ With Elegance, leather includes vertical fluting

It takes many hours of work to make a Mercedes-Benz. In fact, it takes some three weeks just to make a piece of our wood trim. First, special computer-controlled tools slice veneers from the wood, then those closest in colour and grain are selected for the actual trim piece. These thin layers of wood are interspersed with layers of aluminium and clay to ensure stability and durability and affixed to a thin base sheet.

The finished veneer can comprise up to a hundred of these individual layers. Take a closer look at the C-Class and you'll see just how much attention goes into every detail.

SE/EXECUTIVE SE

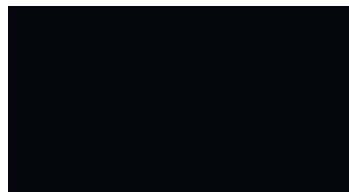

High-Gloss Black



Burr Walnut wood (optional)

ELEGANCE



Eucalyptus wood



Burr Walnut wood (optional)

SPORT/C 63 AMG



Aluminium



Black Bird's-Eye Maple wood (optional)

	NON-METALLIC PAINTS			METALLIC PAINTS									
	Black	Fire Opal	Calcite White	Obsidian Black	Indigolite Blue	Tansanite Blue	Cuprite Brown	Tenorite Grey	Iridium Silver	Palladium Silver	Pearl Beige	Sanidine Beige	
Brighton cloth (SE and Executive SE)													
Black	●	●	●	●	●	●	●	●	●	●	●	●	
Alpaca Grey	●	○	●	●	●	●	○	●	●	○	△	△	
Black/Beige	●	△	△	●	△	△	○	△	△	△	●	●	
Black/Red	●	○	●	●	○	○	○	△	●	△	△	△	
Artico artificial leather (Elegance)													
Black	●	●	●	●	●	●	●	●	●	●	●	●	
Almond Beige	●	○	○	●	●	○	●	△	△	△	●	●	
Alpaca Grey	●	○	●	●	○	●	○	●	●	○	△	△	
Liverpool cloth/Artico artificial leather (Sport)													
Black	●	●	●	●	●	●	●	●	●	●	●	●	
Alpaca Grey	●	○	●	●	●	●	○	●	●	○	△	△	
Artico artificial leather (optional on SE and Executive SE)													
Black	●	●	●	●	●	●	●	●	●	●	●	●	
Alpaca Grey	●	○	●	●	○	●	○	●	●	○	△	△	
Leather (optional on Elegance and Sport)													
Black	●	●	●	●	●	●	●	●	●	●	●	●	
Almond Beige ¹	●	○	○	●	●	○	●	△	△	△	●	●	
Alpaca Grey	●	○	●	●	●	●	○	●	●	○	△	△	
Cognac (Sport only)	●	△	●	●	○	○	○	●	●	○	△	△	

● Recommended

○ Possible

△ Not recommended

¹ For Elegance only

	C 200 CDI BlueEFFICIENCY	C 220 CDI BlueEFFICIENCY	C 250 CDI BlueEFFICIENCY
No. and arrangement of cylinders	4/in-line	4/in-line	4/in-line
Total displacement – cc	2,143	2,143	2,143
Rated output ² – hp (kW) at rpm	136 (100)/2,800	170 (125)/3,000	204 (150)/4,200
Rated torque ² – Nm at rpm (automatic transmission)	360/1,600–2,600 (330/1,600–2,600)	400/1,400–2,800 (400/1,400–2,800)	500/1,600–1,800 (500/1,600–1,800)
Compression ratio	16.2:1	16.2:1	16.2:1
Acceleration from 0–62 mph (automatic transmission)	9.2 (9.7)	8.4 (7.6)	7.0 (7.0)
Top speed, approx. – mph (automatic transmission)	135 (133)	144 (143)	149 (149)
Tyre size front	195/60 R 16	205/55 R 16	205/55 R 16
rear	195/60 R 16	205/55 R 16	205/55 R 16
Fuel consumption ⁴ – mpg (automatic transmission)			
urban	43.5 (38.2)	45.6 (36.2)	42.8 (36.2)
extra-urban	68.9 (64.2)	70.6 (65.7)	67.3 (65.7)
combined	56.5 (51.4)	58.9 (50.4)	55.4 (50.4)
CO ₂ emissions, combined ⁴ – g/km (automatic transmission)	130 (144)	127 (149)	134 (149)
Tank capacity/incl. reserve, approx. – l	66/8	66/8	66/8
Load capacity – l	475	475	475
Turning circle – m	10.84	10.84	10.84
Kerb weight ⁵ – kg (automatic transmission)	1,575 (1,590)	1,610 (1,610)	1,615 (1,615)
Permissible gross vehicle weight – kg (automatic transmission)	2,080 (2,095)	2,115 (2,115)	2,120 (2,120)

¹With ECO start/stop

²Figures according to Directive 80/1269/EEC in the currently applicable version

³Electronically limited

⁴The figures shown were obtained in accordance with the prescribed measuring process (Directive 80/1268/EEC in the currently applicable version).

The figures are not based on an individual model and do not constitute part of the product offer; they are provided solely for purposes of comparison between different vehicle models

⁵Figures according to Directive 92/21/EC, version 95/48/EC (kerb weight with fuel tank 90% full, driver, 68 kg, and luggage, 7 kg) for standard-specification vehicles.

Optional extras and accessories will generally increase this figure and reduce the payload capacity accordingly

C 350 CDI BlueEFFICIENCY	C 180 KOMPRESSOR BlueEFFICIENCY	C 180 CGI BlueEFFICIENCY ¹	C 250 CGI BlueEFFICIENCY	C 350	C 63 AMG
6/V	4/in-line	4/in-line	4/in-line	6/V	8/V
2,987	1,597	1,796	1,796	3,498	6,208
231 (170)/3,800	156 (115)/5,200	156 (115)/5,000	204 (150)/5,500	272 (200)/6,000	457 (336)/6,800
- (540/1,600-2,400)	230/3,000-4,500 -	250/1,600-4,200 (250/1,600-4,200)	- (310/2,000-4,300)	- (350/2,400-5,000)	- (600/5,000)
17.7:1	9.3:1	9.3:1	9.3:1	10.7:1	11.3:1
-(6.4)	9.5	9.0 (9.0)	-(7.4)	-(6.4)	-(4.5)
-(155) ³	143	140 (137)	-(149)	-(155) ³	-(155) ³
225/45 R 17	205/55 R 16	195/60 R 16	205/55 R 16	225/45 R 17	235/40 R 18
225/45 R 17	205/55 R 16	195/60 R 16	205/55 R 16	225/45 R 17	255/35 R 18
- (32.8)	32.8	30.4 (28.0)	-(28.0)	-(19.9)	-(13.9)
-(52.3)	54.3	54.3 (52.3)	-(51.4)	-(38.2)	-(30.1)
-(42.8)	43.5	42.2 (40.4)	-(39.2)	-(28.5)	-(21.1)
-(174)	154	157 (163)	-(168)	-(232)	-(312)
66/8	66/8	66/8	66/8	66/8	66/14
475	475	475	475	475	475
10.84	10.84	10.84	10.84	10.84	11.75
-(1,700)	1,480	1,470 (1,495)	-(1,505)	-(1,610)	-(1,730)
-(2,205)	1,965	1,975 (2,000)	-(2,010)	-(2,095)	-(2,170)



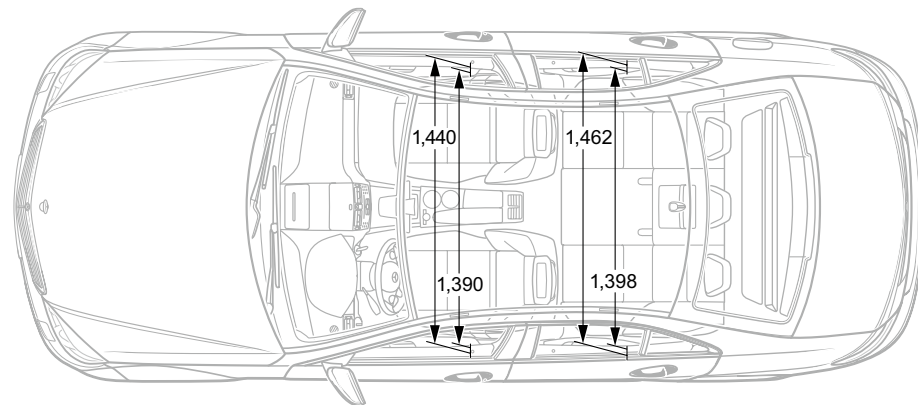
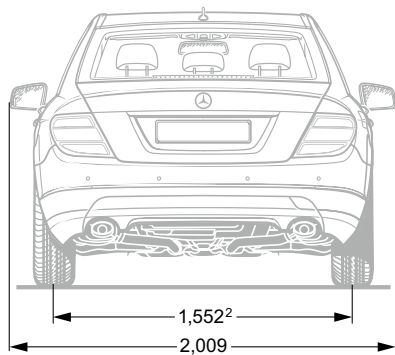
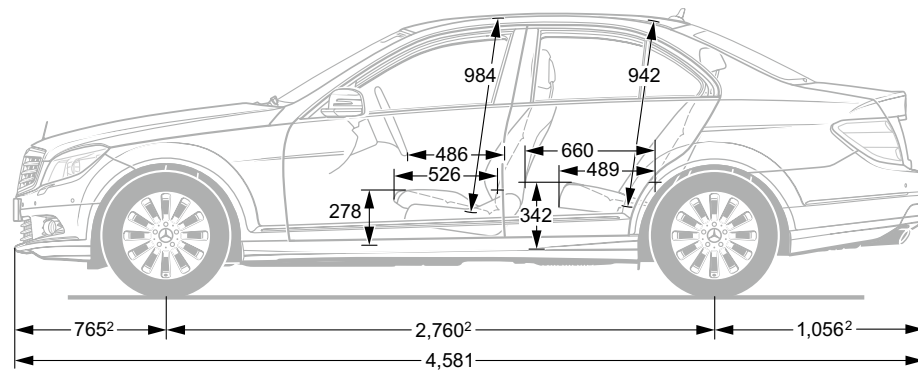
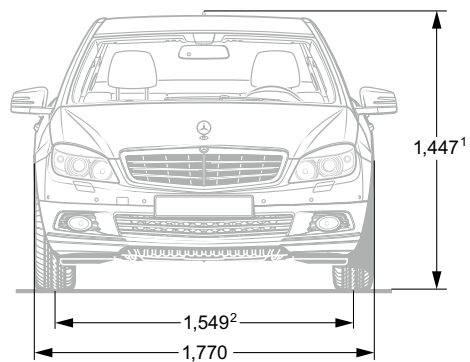

All measurements in millimetres. The dimensions shown are mean values and apply to standard-specification, unladen vehicles

¹ Sport line is 15 mm lower due to sport suspension

² Carrying three people, each weighing 68 kg



	C 200 CDI BlueEFFICIENCY	C 220 CDI BlueEFFICIENCY	C 250 CDI BlueEFFICIENCY
No. and arrangement of cylinders	4/in-line	4/in-line	4/in-line
Total displacement – cc	2,143	2,143	2,143
Rated output ¹ – hp (kW) at rpm	136 (100)/2,800	170 (125)/3,000	204 (150)/4,200
Rated torque ¹ – Nm at rpm (automatic transmission)	360/1,600–2,600 (360/1,600–2,600)	400/1,400–2,800 (400/1,400–2,800)	500/1,600–1,800 (500/1,600–1,800)
Compression ratio	16.2:1	16.2:1	16.2:1
Acceleration from 0–62 mph (automatic transmission)	9.6 (10.1)	8.8 (8.1)	7.8 (7.2)
Top speed, approx. – mph (automatic transmission)	130 (129)	129 (130)	148 (147)
Tyre size front	205/55 R 16	205/55 R 16	205/55 R 16
rear	205/55 R 16	205/55 R 16	205/55 R 16
Fuel consumption ³ – mpg (automatic transmission)			
urban	42.2 (36.7)	44.8 (35.3)	42.2 (35.3)
extra-urban	64.2 (60.1)	68.9 (62.8)	62.8 (62.8)
combined	54.3 (48.7)	57.6 (48.7)	53.3 (48.7)
CO ₂ emissions, combined ³ – g/km (automatic transmission)	137 (153)	130 (154)	140 (154)
Tank capacity/incl. reserve, approx. – l	66/8	66/8	66/8
Load capacity – l	485	485	485
Turning circle – m	10.84	10.84	10.84
Kerb weight ⁴ – kg (automatic transmission)	1,635 (1,650)	1,665 (1,665)	1,675 (1,675)
Permissible gross vehicle weight – kg (automatic transmission)	2,175 (2,190)	2,205 (2,205)	2,215 (2,215)

¹ Figures according to Directive 80/1269/EEC in the currently applicable version

² Electronically limited

³ The figures shown were obtained in accordance with the prescribed measuring process (Directive 80/1268/EEC in the currently applicable version).

The figures are not based on an individual model and do not constitute part of the product offer; they are provided solely for purposes of comparison between different vehicle models

⁴ Figures according to Directive 92/21/EC, version 95/48/EC (kerb weight with fuel tank 90% full, driver, 68 kg, and luggage, 7 kg) for standard-specification vehicles.

Optional extras and accessories will generally increase this figure and reduce the payload capacity accordingly

C 350 CDI BlueEFFICIENCY	C 180 KOMPRESSOR BlueEFFICIENCY	C 180 CGI BlueEFFICIENCY	C 250 CGI BlueEFFICIENCY	C 350	C 63 AMG
6/V	4/in-line	4/in-line	4/in-line	6/V	8/V
2,987	1,597	1,796	1,796	3,498	6,208
231 (170)/3,800	156 (115)/5,200	156 (115)/5,000	204 (150)/5,500	272 (200)/6,000	457 (336)/6,800
- (540/1,600-2,400)	230/3,000-4,500 -	250/1,600-4,200 (250/1,600-4,200)	- (310/2,000-4,300)	- (350/2,400-5,000)	- (600/5,000)
17.7:1	9.3:1	9.3:1	9.3:1	10.7:1	11.3:1
- (6.5)	9.8	9.2 (9.2)	- (7.5)	- (6.5)	- (4.6)
- (152)	138	135 (132)	- (145)	- (155) ²	- (155) ²
225/45 R 17	205/55 R 16	205/55 R 16	205/55 R 16	225/45 R 17	235/40 R 18
225/45 R 17	205/55 R 16	205/55 R 16	205/55 R 16	225/45 R 17	255/35 R 18
- (32.1)	32.8	29.1 (27.4)	- (27.4)	- (19.1)	- (13.8)
- (49.6)	52.3	51.4 (49.6)	- (47.9)	- (38.2)	- (29.4)
- (41.5)	42.8	40.4 (38.2)	- (37.7)	- (28.0)	- (20.8)
- (180)	156	164 (172)	- (175)	- (235)	- (316)
66/8	66/8	66/8	66/8	66/8	66/14
485	485	485	485	485	485
10.84	10.84	10.84	10.84	10.84	11.75
- (1,750)	1,530	1,530 (1,555)	- (1,575)	- (1,655)	- (1,795)
- (2,280)	2,060	2,070 (2,095)	- (2,115)	- (2,185)	- (2,275)



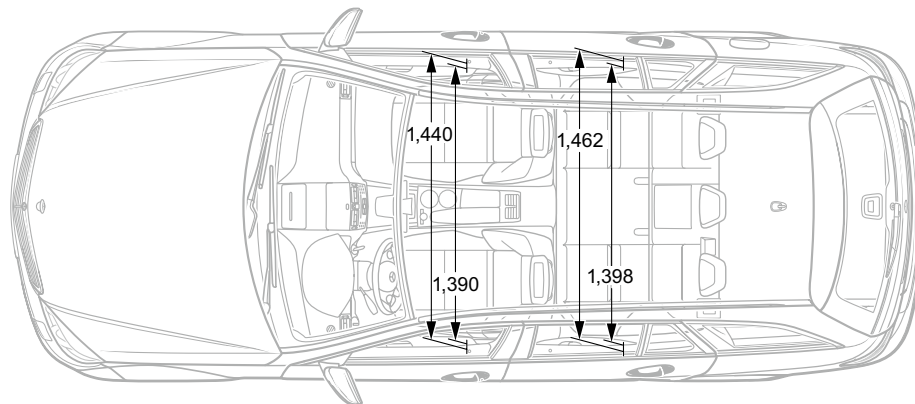
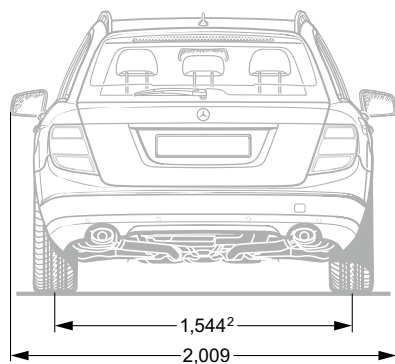
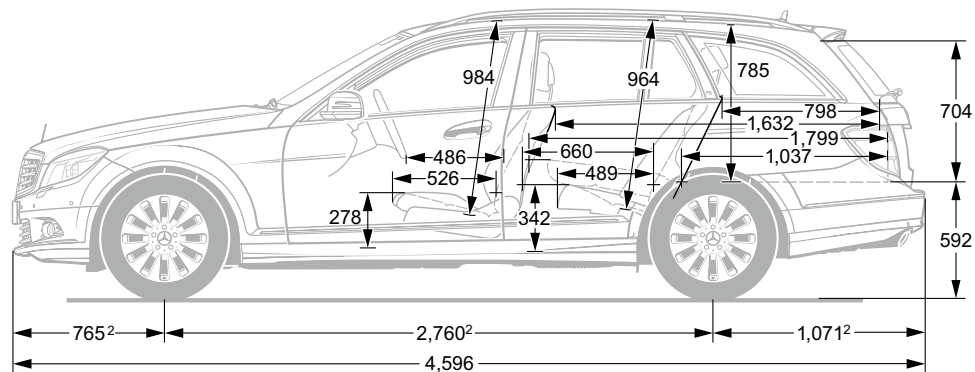
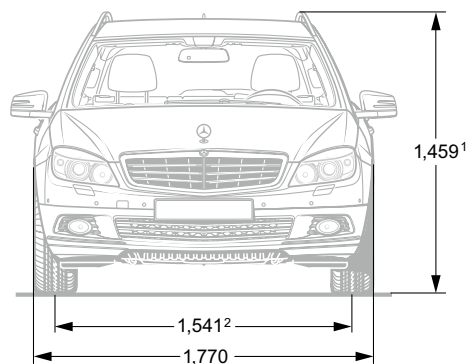

All measurements in millimetres. The dimensions shown are mean values and apply to standard-specification, unladen vehicles

¹ Sport line is 15 mm lower due to sport suspension

² Carrying three people, each weighing 68 kg



The best places to go star-gazing

Mercedes-Benz World and Museum



Mercedes-Benz World at Brooklands

Celebrate the story of Mercedes-Benz and you'll celebrate the story of motoring itself at Mercedes-Benz World in Surrey. A World of experiences. A World of discoveries. A World you will love to explore. Discover Mercedes-Benz racing heritage, its connections to the famous Brooklands circuit and legendary drivers. View, touch and sit in every car from the Mercedes-Benz range, and encounter automotive legends like the 'Gullwing' in the UK's largest Mercedes-Benz showcase. Then set your pulse racing by booking one of our thrilling Driving Experiences. Enjoy AMG performance on the purpose-built Handling Circuits or Wet

Skid Circle, an axle-twisting off-road adventure, or treat your kids to their own drive in an A-Class if they are over 1.5 metres tall. For more interactive action, take a virtual journey along the production line in 'Build' or put your brain to the test in 'Solve'. Relax and refuel in Café 1886, or for a gourmet treat enjoy the first-class menu and elegant surroundings of the Gullwing Restaurant. Finally, extend your visit with a short stroll to Brooklands Museum to see their collection of classic cars, aviation exhibitions – and the legendary Concorde.

For more information visit
www.mercedes-benzworld.co.uk



Mercedes-Benz Museum

More than 120 years of automotive history in one place – the Mercedes-Benz Museum in Stuttgart-Untertürkheim. With a total exhibition area of 16,500 square metres, it transports the visitor to a fascinating world of automotive achievement. You can see the first modern motor car, the Mercedes Simplex, discover over 100 years of motor-racing history, and, of course, admire our classics, such as the ‘Gullwing’ and the ‘Tail Fin’. Legendary cars such as these have always occupied a special place in the hearts of car enthusiasts. Now they have a special place of their own in the Mercedes-Benz Museum. We look forward to welcoming you there soon.

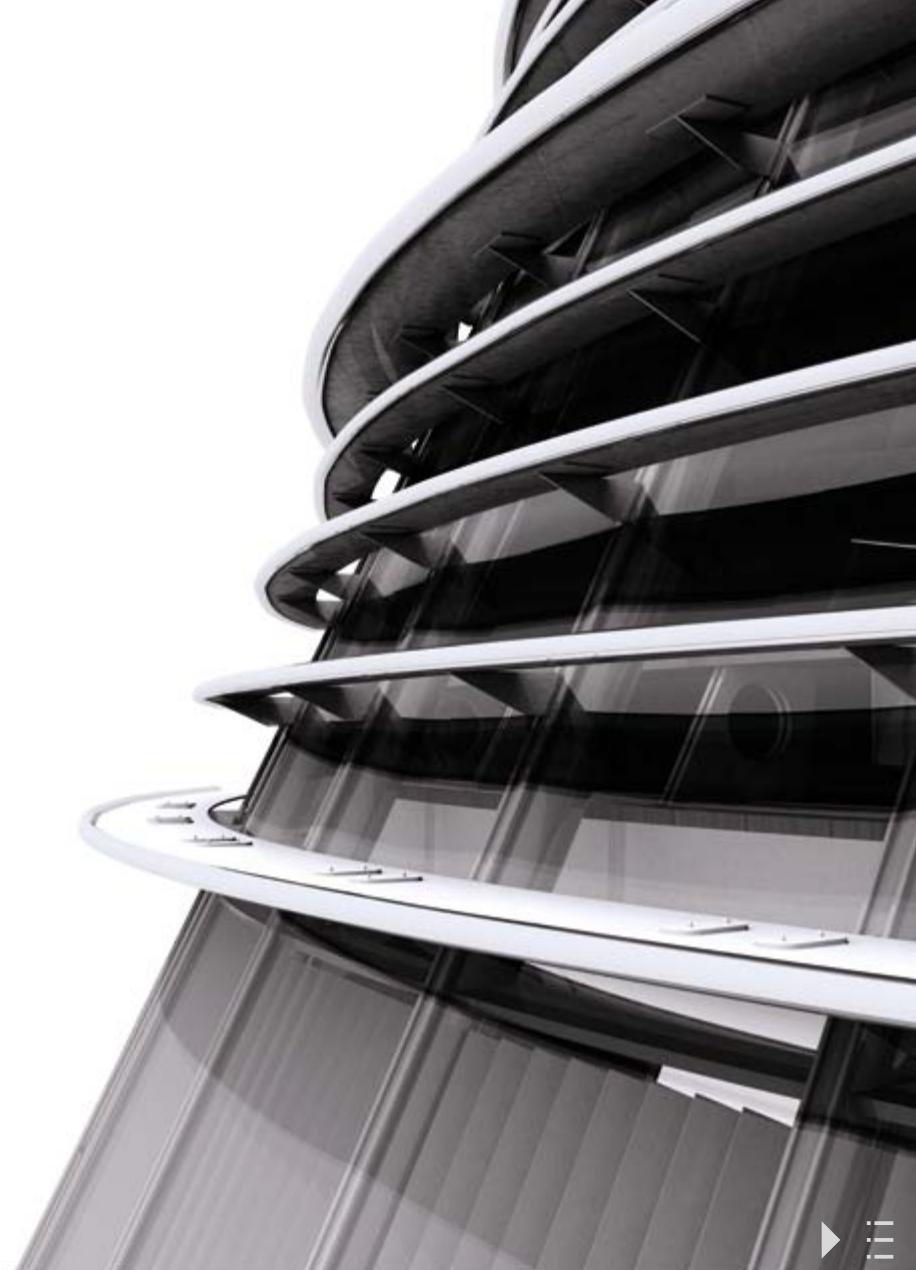

Following the star

Mercedes-Benz Roadside Assistance

Rest assured that should you ever need help, Mercedes-Benz Roadside Assistance is there for you. In the unlikely event of a technical breakdown,¹ you can rely on the Mercedes-Benz Roadside Assistance Team – anywhere in Europe. Simply phone our Customer Assistance Centre on 00800 1 777 7777,² where our specialists will organise assistance for you.

Mercedes-Benz will also assist you in the event of a minor mishap preventing you from driving your vehicle.³ Whether you lose your key, run out of fuel or your vehicle is damaged due to an accident or vandalism, we ensure that you still reach your destination.

¹ Technical breakdown cover is initially valid for your vehicle for four years from the date of first registration. This can be extended from the fifth year, up to a maximum of 30 years, on completion of each scheduled maintenance service, providing that this service is carried out by a Mercedes-Benz Official Workshop

Often the problem can be rectified on the spot, but if this is not possible we will naturally ensure that your vehicle is taken to the nearest Mercedes-Benz Official Workshop to get you back on the road as quickly as possible.

² In non-affiliated European countries: +49 69 9530 7277

³ This cover can be retained from the fifth year. Your Mercedes-Benz Official Workshop will provide details of how to renew this cover once your initial four year term has expired



To be continued. With a test drive

A Mercedes-Benz is most at home on the road. This is the only way to experience the effortlessly superior driving feel that lends every Mercedes model its inimitable class. Feel the power of the efficient engines with low fuel consumption, and precise steering designed to really put you in the mood for driving. And experience what true comfort really feels like. The unique feeling of driving a Mercedes cannot be put into words, however. Which is why we'd like to invite you to take a test drive. Your Mercedes-Benz Retailer will be happy to make all the necessary arrangements for you. Simply visit www.mercedes-benz.co.uk/testdrive to request a test drive. We look forward to seeing you.

Interactive Owner's Manual

The website also offers an interactive tour, enabling you to take a closer look at your desired model. This simulation is the ideal way to acquaint yourself with your dream car. You can view key functions in detail, gain an insight into the car's inner workings or look at the benefits of each model. For further details, visit

www.mercedes-benz.co.uk/cclasssaloonmanual

www.mercedes-benz.co.uk/cclassstatemanual

Take-back of end-of-life vehicles. Coming full circle. At the end of its long life, you can return your C-Class to us for environment-friendly disposal in accordance with the EC End-of-Life Vehicle Directive.¹ But that day lies a long way off.

¹Applies in accordance with national regulations to vehicles up to 3.5 tonnes gross weight. The C-Class has met the statutory regulations governing the suitability of their design for reuse and recycling for a number of years now. A network of vehicle take-back depots and dismantlers has been established which will process your vehicle in an environment-friendly manner. The ways in which both vehicles and parts can be recovered are subject to ongoing development and improvement. Consequently, the C-Class will be able to comply with any future increases in the recycling quota within the stipulated time limits. Further information is available at www.mercedes-benz.co.uk or by calling 0808 156 6606.

Please note: this online version of the printed brochure may contain abridged copy or other content changes. The manufacturer reserves the right to make changes to the design, form, colour and specification during the delivery period, provided these changes, while taking into account the interests of the vendor, can be deemed reasonable with respect to the purchaser. Where the vendor or the manufacturer uses symbols or numbers to describe an order or the subject of an order, no rights may be derived solely from these. The illustrations may show accessories and items of optional equipment which are not part of standard specification. Colours may differ slightly from those shown. This brochure provides a general indication of the range of models, features, optional extras and/or colours available in various countries. Some of the models, features, optional extras and/or colours shown may not be available in your country or may only be available in a different specification. Additionally, some models, features, optional extras and/or colours may only be available in combination with others. For current and more specific information in relation to the range of models, features, optional extras and/or colours available in your country, and their pricing, you should contact your nearest authorised Mercedes-Benz Retailer. E&OE.
www.mercedes-benz.co.uk

